

HYDRAULIC PUMPS & ACCESSORIES

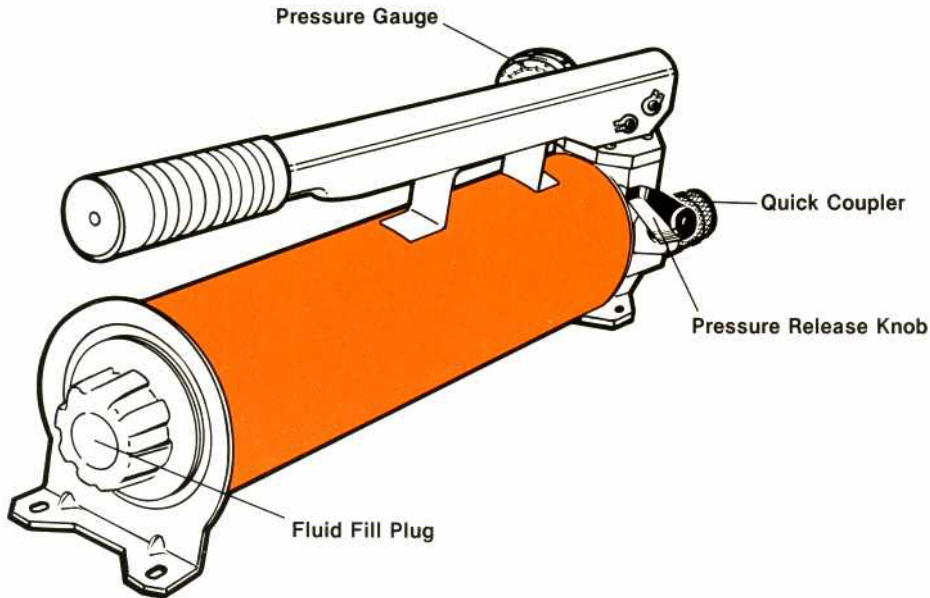

2 Stage Hydraulic Hand Pump For Model 402 & 401 Kits

140 Cubic Inch Oil Reservoir Capacity

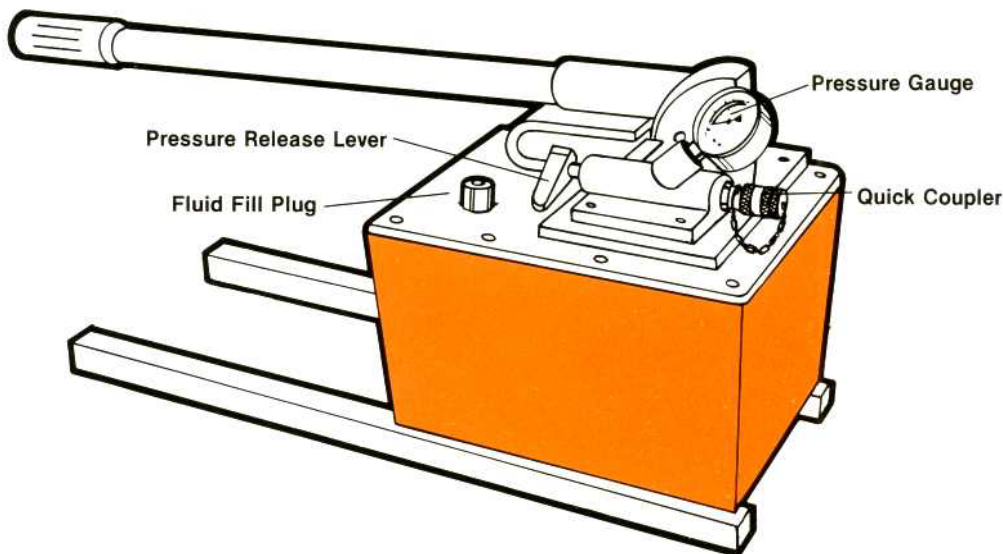

2 Stage Hydraulic Hand Pump For Model 802 & 801 Kits

460 Cubic Inch Oil Reservoir Capacity

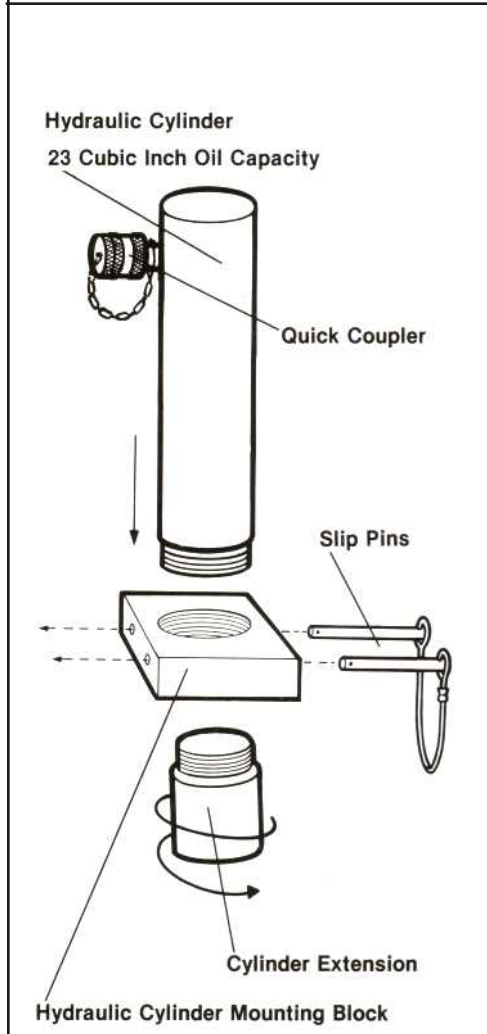
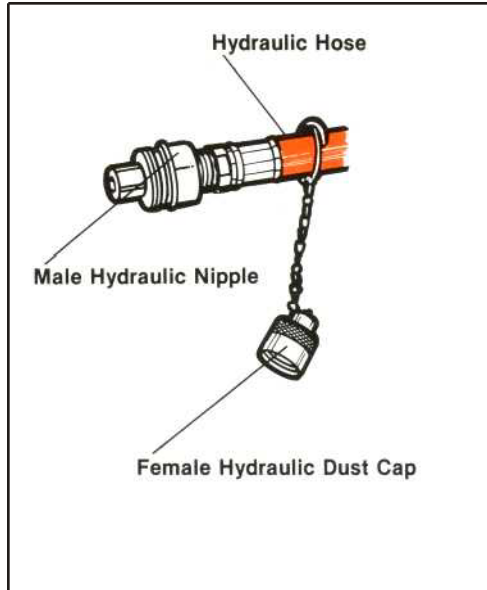

PIPE-CHOKE™ HYDRAULIC ACCESSORIES

PART DESCRIPTION	PART #
10 Ton Hydraulic Cylinder	H 473
2 Stage Hydraulic Pump (For use with 401 and 402)	H 455
2 Stage Hydraulic Pump (For use with 801 and 802)	H 467
Hydraulic Hose 2ft. (Complete with Coupler & Dust Cap)	H 419
Hydraulic Hose 10ft. (Complete with Couplers & Dust Caps)	H 406
Hydraulic Hose 20ft. (Complete with Couplers & Dust Caps)	H 435
Quick Disconnect Coupler	H 421
Hydraulic Male Coupler	H 498
Hydraulic Dust Cover (Male)	H 482
Hydraulic Dust Cover (Female)	H 403
High Pressure Hydraulic Tee	H 427
Pressure Gauge (O# - 10,000#) Dampened	H 452
Hydraulic Cylinder Mounting Block	P 278
Slip Pins	P 241
Hydraulic Cylinder Extension	P 293



1309 Main Street Crescent, PA 15046 Fax 724-457-1200 724-457-6193 1-800-258-7899

Visit our web site: www.qtektools.com