

NEW, COMPACT, DURABLE



Q-TEK™
MODEL 200
PIPE CHOKE™ TOOL

PIPE CHOKE™ MODEL 200

Q-TEK's compact squeeze-off tool, the Model 200 Pipe Choke, is designed for use with ½" - 2 IPS polyethylene pipe. Built for durability and ease of operation, the Model 200 weighs only 7 lbs.

Stop blocks are available for all polyethylene pipe sizes for proper squeeze-off and minimal pipe damage.

Stainless steel marker and rounding clamps also are available to aid in support and identification of squeezed areas.

Grounding straps are available for all Pipe Choke machines.

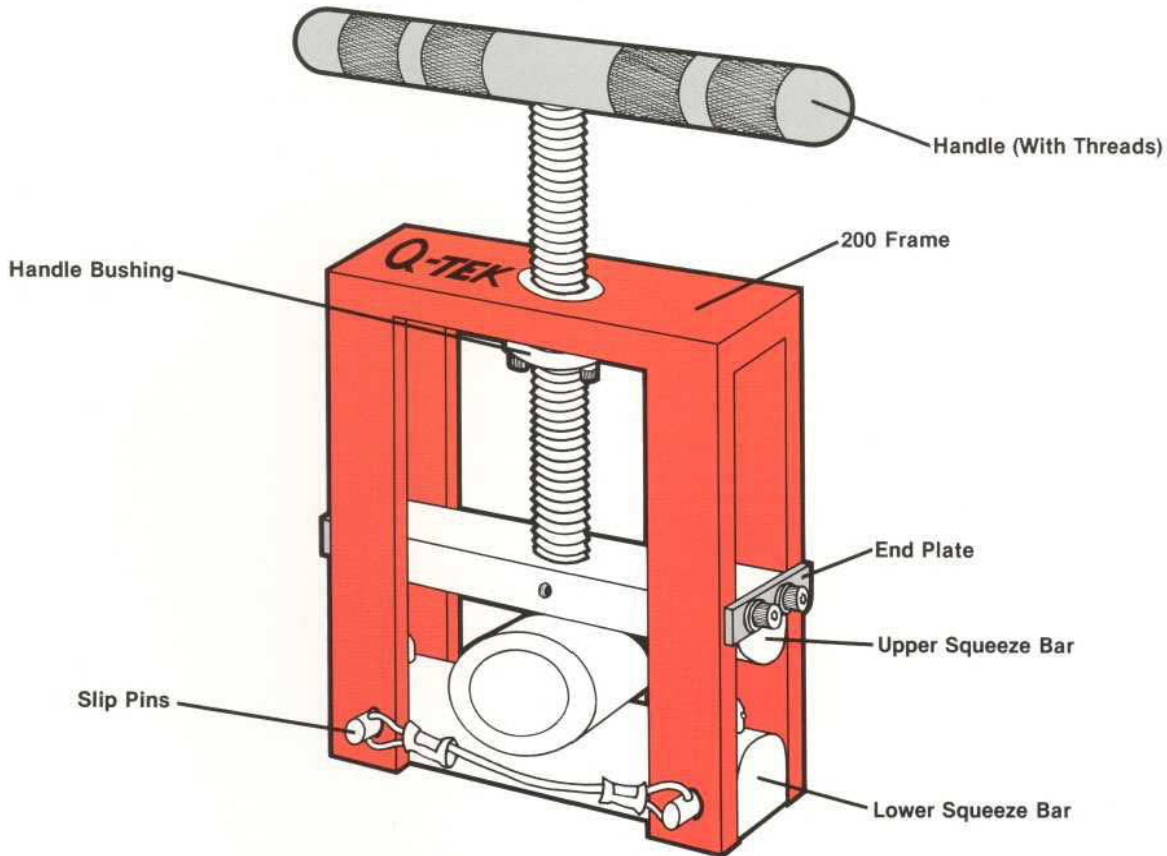

MODEL 200 MANUAL PIPE CHOKE™ EQUIPMENT PARTS

PART DESCRIPTION	QUANTITY	PART #
200 Frame (Frame Only)	1	P 205
Upper Pipe Choke Squeeze Bar	1	P 245
Lower Pipe Choke Squeeze Bar	1	P 253
Handle (with threads)	1	P 296
Lower Pipe Choke Squeeze Bar End Plate	2	P 221
Handle Bushing	1	P 227
Slip Pins	1	P 267
200 Pipe Choke (Complete)	1	P 281



1309 Main Street Crescent, PA 15046 Fax 724-457-1200 724-457-6193 1-800-258-7899

Visit our web site: www.qtektools.com